

# Car-Pro

By:



Professional Vehicle Security

## CPX-2200

### INSTALLATION & OPERATIONS MANUAL

**AUTOPAGE INC.**  
 1815 West 205<sup>th</sup> Street Suite 101  
 Torrance, California 90501-1525  
 Main Office: 310-618-2002  
 Customer Service: 800-262-2527 Ext. 462  
[www.autopageusa.com](http://www.autopageusa.com)

## CPX-2200 WIRE DIAGRAM

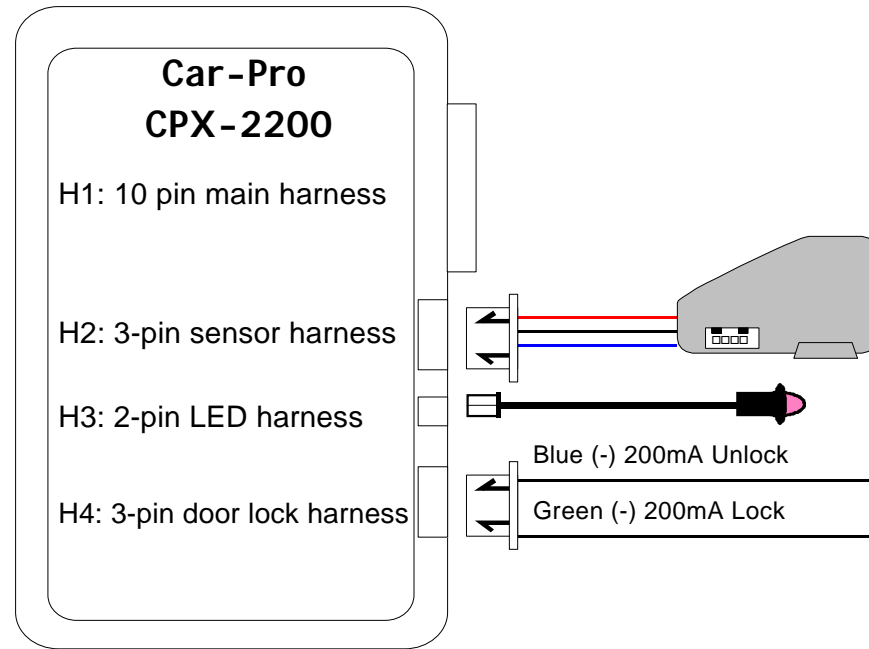

### H1: 10 PIN HARNESS

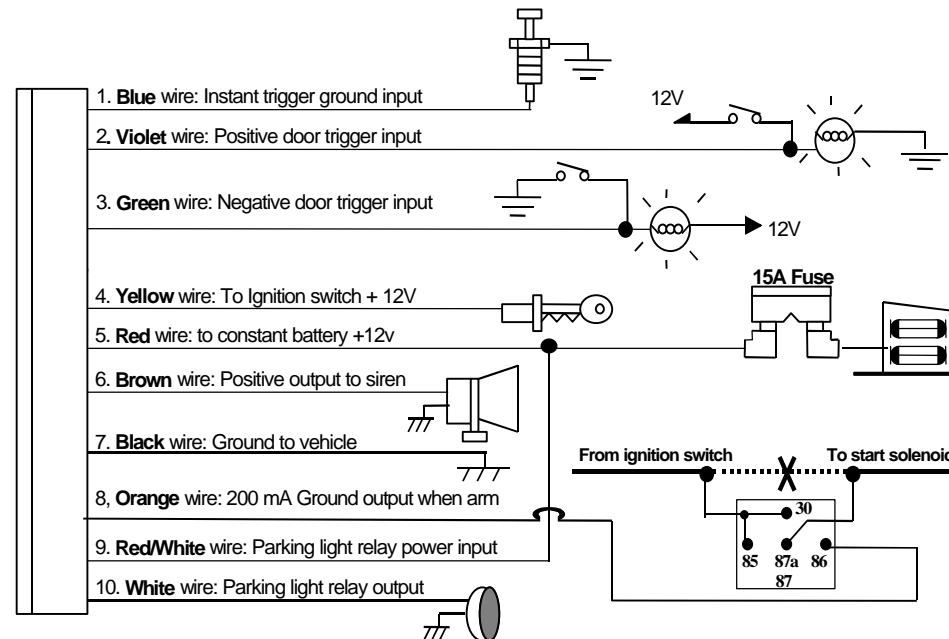

## PROGRAMMING

### A. TRANSMITTER CODE LEARNING:

**Note:** This security system will only retain the last 4 remote transmitters programmed. If the transmitter memory is exceeded, the security system will start deleting transmitters from memory in chronological order.

1. Disarm the system.
  2. Open the Door and keep the door open
  3. Turn the ignition key " OFF / ON " 6 times, keep at "ON" position at 6<sup>th</sup> time switching, you will get 6 chirps to confirm enter transmitter programming.
  4. Within 15 seconds press & hold any button for transmitter code learning, a long chirp confirm transmitter programmed.
  5. Apply steps 4 – 5 to program 2<sup>nd</sup>, 3<sup>rd</sup> and 4<sup>th</sup> transmitter.
- Exit:** Turn the ignition off, 3 long chirps confirm exit.

### B. FEATURE PROGRAMMING

1. Disarm the system.
2. Open the Door and keep the door open.
3. Turn the ignition key " OFF / ON " 3 times stay in on position. (3 chirps to confirm in programming mode)
4. Within 15 seconds press button " I + II " to select the feature which you want to program. See the features programming table below to select the desired features, which you want to program. Note the number of siren chirps to confirm the selected feature(s).
5. Press the button " I " or " II " on the transmitter to enable or disable the specific feature.
6. Repeat steps 4 - 5 for any other features you wish to program.

Number of pressing button I + II & chirps	Program feature	Press button " I " / one long chirp <b>Factory Setting</b>	Press button " II " / Two long chirps
1	Time for door lock	0.9 sec.	3.5 sec.
2	Passive Door Lock	Disable	Enable
3	Ignition lock	Enable	Disable
4	Anti car-jacking	Disable	Enable
5	Door Ajar Warning	Enable	Disable

**Exit:** Turn the ignition off, or close the door, 3 long chirps confirm exit.

### C. PASSWORD SETUP:

1. Disarm the system.
2. Open the Door and keep the door open
3. Turn the ignition key " OFF / ON " 9 times for "New Password Pin Code Setting" and keep at "ON" position at 9<sup>th</sup> time switching.
4. After 2-second pause, the siren will chirp 9 times to confirm entry.
5. Within 15 seconds, begin to enter your chosen 1 – 9 digit by pressing and releasing the transmitter button "I" from 1-9 times
6. Press button " II " to get out of password setup mode, corresponding to the new password code report by siren chirp confirmation.

**Note:** Default setting of password code from the factory is " 1".

# CPX-2200 OPERATION MANUAL

## TRANSMITTER OPERATION:

Transmitter Button	Feature	Remark
Button	Arm / Door lock	
-  Button	Arm and Delete Optional Sensor	Press twice within 3 seconds.
Button	Car Locator	Under arm mode
Button for 3 seconds	Panic	Press & hold 3 seconds
Button	Disarm & door unlock	
Button for 2 seconds	In or Out Passive mode	Press & hold 2 seconds
+  Button	Silent arm / disarm	<b>Under ignition off</b>
+  Button for 2 seconds	Anti car-jacking	<b>Under ignition on</b>

### A. ACTIVE ARMING – LOCK & ARM:

- Press button on transmitter.
- The siren chirps once and parking lights flash once indicating the system is now armed. The vehicle doors will lock upon arming when interfaced with the security system.

**DOOR AJAR WARNING:** When you arm the system and the siren chirps 3 times, it means you have left a door or trunk, or hood lid ajar. You should check and find out the defective protecting point.

**SHOCK SENSOR / OPTIONAL SENSOR BY-PASS:** Press button twice within 3 seconds to arm the security system, by-pass shock sensor connected to 3-pin plug. The system will chirp one additional time to confirm the sensor bypass mode was activated. The sensor bypass feature is programmed to activate for one arming cycle only. The security system will return to the original program setting for the next arming cycle.

**SILENT ARMING / DISARMING:** Press + button together to arm or disarm your security system. No chirp sound will be heard; arm / disarm confirmation will be through the vehicle's parking lights only.

### B. PASSIVE ARMING

This system is equipped with passive arming feature, which allows the system to arm itself in 30 seconds after the last door is closed; operation is as follows:

- Turn ignition to OFF position and exit the vehicle
- After all entrances are closed, the system will start counting and LED flashes for 30 sec., if you re-open any door / trunk / hood the system will stop counting and the LED will stop flashing. It will start re-counting again once all vehicles' entrances are closed.
- After 30 seconds has elapsed, the security system will automatically "ARM". The siren will chirp once and the parking lights will flash once.

### REMOTE PASSIVE:

You can use the remote transmitter to both enter and to exit the passive mode, eliminating the need to hand your transmitter to parking attendants or garage mechanics.

a). Press and release button for 2 seconds. The system will enter the passive mode. One long chirp confirms entry to the passive mode.

b). Press and release button for 2 seconds. The system will exit the passive mode. Two long chirps confirm exit of the passive mode.

### PASSIVE DOOR LOCKING

The vehicle doors will automatically lock after passive arming cycle has been completed.

### C. ACTIVE DISARMING – UNLOCK & DISARM:

Press button on the transmitter, the siren will chirp twice and parking lights will flash twice to indicate the security system is now disarmed. The vehicle doors will unlock when interfaced with the security system.

**TAMPER DISARMING:** If the alarm has been triggered, upon disarming the system, the siren will chirp 4 times and the parking lights will flash 3 or 4 times.

**AUTO RE-ARM:** The security system will auto re-arm itself within 30 seconds after disarming by remote transmitter. Auto re-arm will be canceled if any protected door has been opened before the 30 seconds timer has elapsed.

### PANIC FUNCTION:

The transmitter can be used as a remote panic switch to manually trigger the alarm in case of emergency.

- Under the arming mode press and hold button for over 3 seconds. The siren will sound and the parking lights will flash.

To stop the panic mode press or button and the panic mode will turn off immediately.

If the button is not pressed, the alarm will automatically stop in 30 seconds.

### D. TRIGGER THE SYSTEM

When the alarm system is armed, your vehicle is protected as follows:

- Light impact will trigger the warn-away signal. A long chirp from siren.
- Heavy impact / Door open / Hood open / Trunk open / Turning on the ignition switch; all will trigger the programmed sequence.

For above (2) The siren and parking light will turn on, alerting of an intrusion for 30 seconds. Then it will stop and automatic reset / re-arm. If any one of the sensors or detectors is still active, the alarm system will sound a maximum of 3 times of 30 seconds cycles. The starter disable relay (if installed) prevents the vehicle's starter from cranking.

### E. ANTI CAR - JACKING

**Warning:** If you don't need anti car-jacking function in this alarm system, be sure to set anti car-jacking feature "DISABLE". This system is default setting all anti car-jacking "DISABLE".

- With the Ignition "on", press and hold + button on the transmitter for over 2 seconds.

The parking light will turn on for 2 seconds to indicate activation of anti car – jacking mode.

- TRIGGER THE ANTI CAR - JACKING MODE:

#### 3-timer circuits will function as follows:

##### First timer:

- 50 seconds after the system has been triggered, the siren will start chirping for 15 seconds.

- During this 15 seconds period of chirping, you will be alerted to press and hold + button on the transmitter for over 2 seconds to turn off the anti car-jacking feature; parking lights will flash twice and siren will chirp twice confirming success in turning off the anti car-jacking mode.

- If not, it will enter the second timer of anti car- jacking feature

##### Second timer:

65 seconds after the system has been triggered. The siren start sounding and the parking lights will start flashing.

##### Third timer:

90 seconds after the system has been triggered

- The siren will continue sounding and the parking lights flashing, and
- The starter disable will activate to prevent vehicle from starting.
- It will remain active until the vehicle's battery power exhausted.

### F. DISARMING WITHOUT A TRANSMITTER

The Override function may be used if the remote transmitter is lost or inoperative.

- Turn ignition switch to 'ON' position and the LED will start flashing, indicating the system has entered the password override mode.

Once the LED has flashed the same number of times as your password number, then turn the ignition key "OFF"; the alarm will stop sounding and enter the disarm mode. You can now start and operate the vehicle normally.

#### Example: If your programmed Password Code is " 5 " you would;

- Turn the ignition switch to the 'ON' position and the LED will start flashing, indicating the system has entered the password override mode.
- Wait until the LED flashes for the 5th time, then the turn ignition key OFF immediately.

The alarm will stop sounding and enter the disarm mode. You can now start and operate the vehicle normally.

### G. IGNITION CONTROL DOOR LOCK.

If the vehicles' door locks have been interfaced to the security system, the system will automatically lock the vehicle's door when the ignition "ON" and unlock vehicle's door when ignition "OFF".

### H. CAR LOCATOR

Under the armed mode press button to activate car locator, siren will chirp 6 times and parking lights flash 12 times for you to easily locate your car.

### LED INDICATORS:

LED	Function
Off	Disarmed
Slow flash	Armed
Fast flash	Passive arming

### CHIRP INDICATORS:

Chirp	Function
1 chirps	Arm
2 chirps	Disarm
3 chirps	Door ajar warning
4 chirps	Disarm / system trigger
6 chirps	Car locator

### PARKING LIGHTS:

Parking light	Function
1 flash	Arm
2 flashes	Disarm
3 flashes	Disarm / trigger on ignition or door pin switch
4 flashes	Disarm / trigger on shock sensor
12 flashes	Car locator

### ALARM OPERATION CONDITIONS:

	Siren	Parking Light	LED	Door	Starter "CUT"
Arming	1 or 3 Chirps	1 Flash	Slow Flash	Locking	On
Disarming	2 or 4 Chirps	2 or 3 or 4 Flashes	Off or Fast Flash	Unlocking	Off
Trigger	Alarming	Flashes	Slow Flash		On
Panic	Alarming	Flashes	Slow Flash		On